

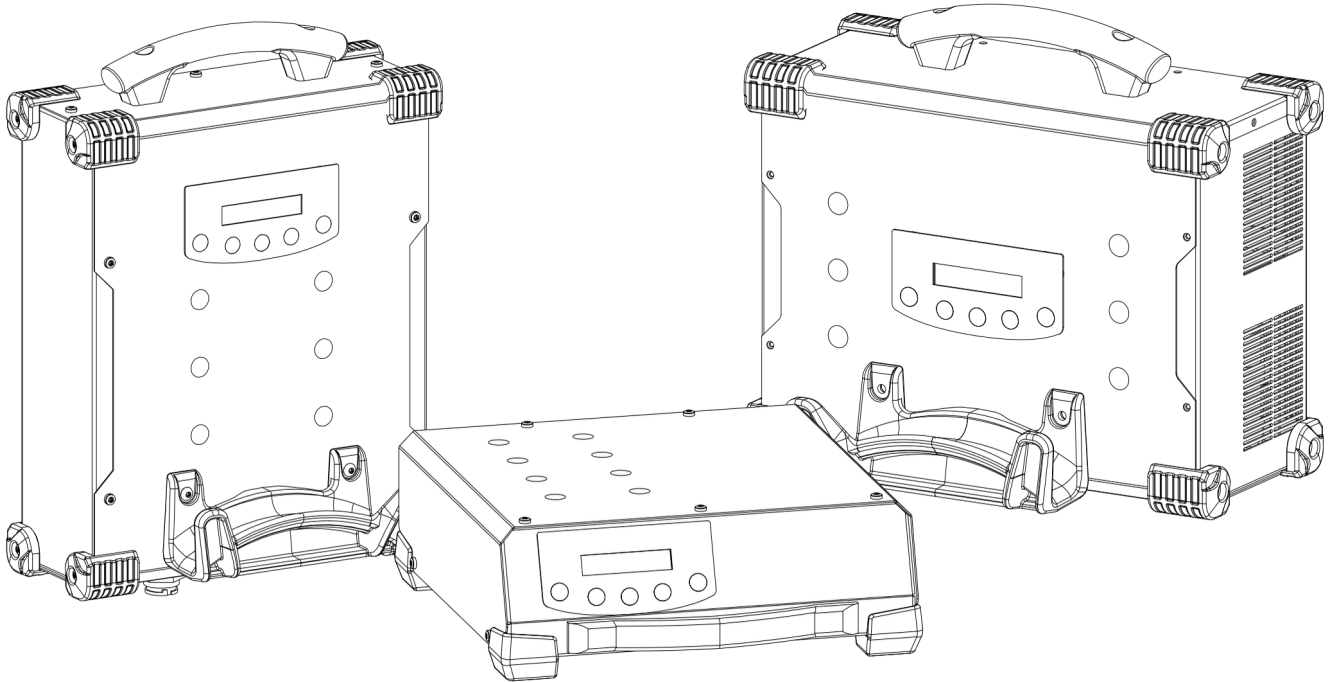

INNOVATIVE
CRTE



EN 17-31 / 107-112

GYSFLASH

- 51.12 CNT FV
- 101.12 CNT FV
- 103.12 CNT FV
- 121.12 CNT FV
- 123.12 CNT FV
- 125.12 CNT FV
- 53.24 CNT FV
- 101.24 CNT FV
- 103.24 CNT FV
- 25.48 CNT FV
- 51.48 CNT FV
- 53.48 CNT FV

**SALES
SERVICE
SUPPORT**

(973) 768-9812

WWW.INNOVATIVECRTE.COM

101 Alexander Ave, Suite 2
Pompton Plains, NJ 07444

SAFETY INSTRUCTIONS



This manual contains safety and operating instructions. Please read it carefully before using the device for the first time and keep it for future reference. This machine should only be used for charging or power supply operations specified within the limits indicated on the machine and in the instruction manual. The operator must observe the safety precautions. In case of improper or unsafe use, the manufacturer cannot be held liable.



The device is destined to be used indoors. Must not be exposed to the rain.

This unit can be used by children aged 8 or over and by people with

reduced physical, sensory or mental capabilities or lack of experience or knowledge, if they are properly monitored or if instructions for

using

the equipment have safely been read and potential risks understood. Children must not play with the product. Cleaning and maintenance should not be performed by an unsupervised child.

Do not use to charge domestic batteries or non rechargeable batteries.

Do not use the charger if the mains cable or plug is damaged.

Do not use the device if the charging cable appears to be damaged or assembled incorrectly in order to avoid any risk of short circuiting the battery.

Never use on a frozen or damaged battery.

Do not cover the device.



Do not place the unit near a heat source or expose to prolonged high temperatures (above 60°C). Do not obstruct the cooling vents. The operating mode of the automatic charger and the restrictions applicable to its use are explained later in this manual.

Fire and explosion risks!

- Avoid flames and sparks. A battery can emit explosive gases when on charge.
- Protect the electrical contact surfaces of the battery against short circuits. During the charge, the battery must be placed in a well-ventilated area.

Do not leave a charging battery unattended for a long time.

Risk of acid dispersion!



- Wear protective goggles and gloves.



- In case of contact with the eyes or the skin, rinse immediately with water and see a medical doctor as soon as possible.

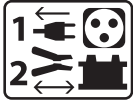

Connection / disconnection :

- Disconnect the power supply before plugging or unplugging the connections to/from the battery.
- Always ensure the Red clamp is connected to the «+» battery terminal first. If it is necessary to connect the black clamp to the vehicle chassis, make sure it is a safe distance from the battery and the fuel line. The charger must be connected to the mains.
- After charging, disconnect the charger from the mains, then disconnect the negative clamp from the car body and then disconnect the positive clamp from the battery, in this order.



Connection :

- The charger must be connected to an earthed power supply.
- The connection to the power supply must be carried out in compliance with national standards.



Maintenance :

- If the power supply cable is damaged, the replacement cable must be obtained from the manufacturer or its service team.
- Maintenance should only be carried out by a qualified person.
- Warning ! Always disconnect from the mains before performing maintenance on the device.
- The device does not require any specific maintenance.
- If the internal fuse is melted, it must be replaced by the manufacturer (GYS dedicated sales service) or by an equally qualified person to prevent any accidents.
- Do not use solvents or any aggressive cleaning products.



Regulations :

- The Machine is compliant with European directives.
- The declaration of conformity is available on our website.



- EAEC Conformity marking (Eurasian Economic Community).



- RCM conformity mark for Australia and New Zealand.



- Equipment in compliance with British requirements. The British Declaration of Conformity is available on our website (see home page).



- Equipment in conformity with Moroccan standards.
- The declaration C₂ (CMIM) of conformity is available on our website (see cover page).



- Equipment complying with Chinese requirements on the restricted use of hazardous substances in electrical and electronic products.



Waste management:

- This product should be disposed of at an appropriate recycling facility. Do not throw away in a household bin.

GENERAL DESCRIPTION

Your GYSFLASH is a professional multifunctional charger with Inverter technology. Designed to support the batteries of demonstration vehicles or during the diagnostic work, it also guarantees an ideal quality of charge for the maintenance of the most advanced models. This charger can be fitted with cables up to 8 m long. Changing the charging cables requires recalibration (see page 21). It is considered a fixed device not a mobile product.

Your GYSFLASH is supplied with a software that includes 5 different modes to choose from:

- **Pb-Charge Mode** : dedicated to recharging lead-acid starter batteries (sealed, liquid, AGM, etc.).
- **Li-Charge Mode** : dedicated to recharging lithium starter batteries (LiFePO4).
- **Power mode | Diag+** : Supplies the energy required during diagnostic work on the vehicle.
- **Power mode | Showroom** : Maintains the charge of the battery and supplies the energy required when using the consumers of a demonstration vehicle.
- **Tester Mode**: Used to check the state of the battery and test the vehicle starting system and alternator.

Your GYSFLASH is SMART!

The original features of your GYSFLASH can be extended by adding specific charging modes and profiles using the USB port and custom settings (see page 24).

Your GYSFLASH also offers the possibility to recover data from several hundred charging operations on your USB stick for analysis on a spreadsheet.

Additional modules (such as printer, Ethernet port, etc.) can also be connected to the charger via its dedicated module socket.

Auto-Detect» function:

The GYSFLASH is equipped with the «Auto-Detect» function which automatically starts a charge when a battery is connected to the charger. (To enable/disable this function see page 24)

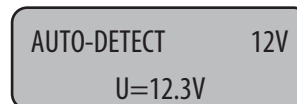

Auto-Restart» function:

The «Auto-Restart» function offers the possibility of automatically restarting the charger in the event of a power failure. (To enable/disable this function see page 24)

«Lock» function:

It is possible to lock the buttons on your GYSFLASH when it is used in a place open to the public or unattended. To activate/deactivate the lock, press and hold ▲ and ▼ for 3 seconds.

START UP

1. Connect the charger to the mains.
2. Set the switch, located at the back of the charger, to «ON».
3. Select the desired mode (Pb-Charge -> Li-Charge -> Showroom -> Diag+ -> Tester).

To access the «configuration» menu press the **MODE** key for 3s :

CHARGE MODE

● **Setting the mode:**

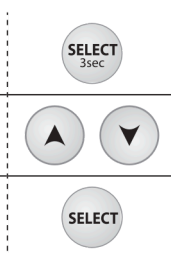

- 1 Press the SELECT button for 3 seconds to activate the modification of the mode settings.
- 2 Use the arrows to change the value of the parameter.
- 3 Press the SELECT button to accept the value and move to the next parameter.



- 1- Type of charge
- 2- Charge profile
- 3- Rated battery voltage
- 4- Rated battery capacity

Charge type:	Profil	Charging voltage	
Pb-CHARGE	normal	2.40 V/cell	Lead batteries of the types Gel, MF, EFB, SLA...
	AGM	2.45 V/cell	Most AGM lead-acid batteries including START and STOP. However, some AGM batteries require a lower voltage charge (Normal profile). Check the battery manual if in doubt.
	water	2.45 V/cell	Open liquid-type lead-acid batteries with cap.
	Easy	2.40 V/cell	Profile dedicated to lead batteries that automatically adapts the charging current according to the size of the battery. However, for maximum charge optimization, it is recommended, when possible, to use normal, AGM or liquid charge curves.
Li-CHARGE	LFP/LiFePO4	3.60 V/cell	Lithium batteries type LFP (Lithium Ferro Phosphate)

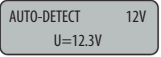
• Start of the charge:

<p>1 To start the charge, press the START/STOP button.</p> <p>If the AUTO-DETECT function is active, charging will start automatically after 3 seconds if a battery is present.</p>	 	<p>1- Battery voltage 2- Progress of the charging cycle 3- Current delivered by the charger 4- Ampere hours supplied 5- Duration</p>
<p>2 During charge, your GYSFLASH indicates the percentage of progress of the charging cycle and alternately the voltage, current, amps hour supplied and the duration.</p>		
<p>3 Press the START/STOP button to stop the charge.</p>		

• SOS function

This function is used to force the charging process to start in the event of an extremely discharged lead-acid battery. To do this, press the START/STOP button for 3 seconds. The 'SOS mode' indication will be displayed for 3 seconds before charging is forced.

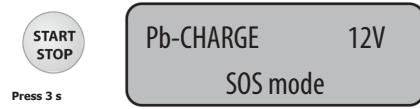

Precautions :

When charging a vehicle, it is recommended to reduce the vehicle power consumption to a minimum (switch off the lights, switch off the ignition, close the doors, etc.) in order not to disturb the charging process.
 Precaution: Check the electrolyte level of any open battery. Fill it up if necessary, before starting the charge.

• Lead-acid charging curve:

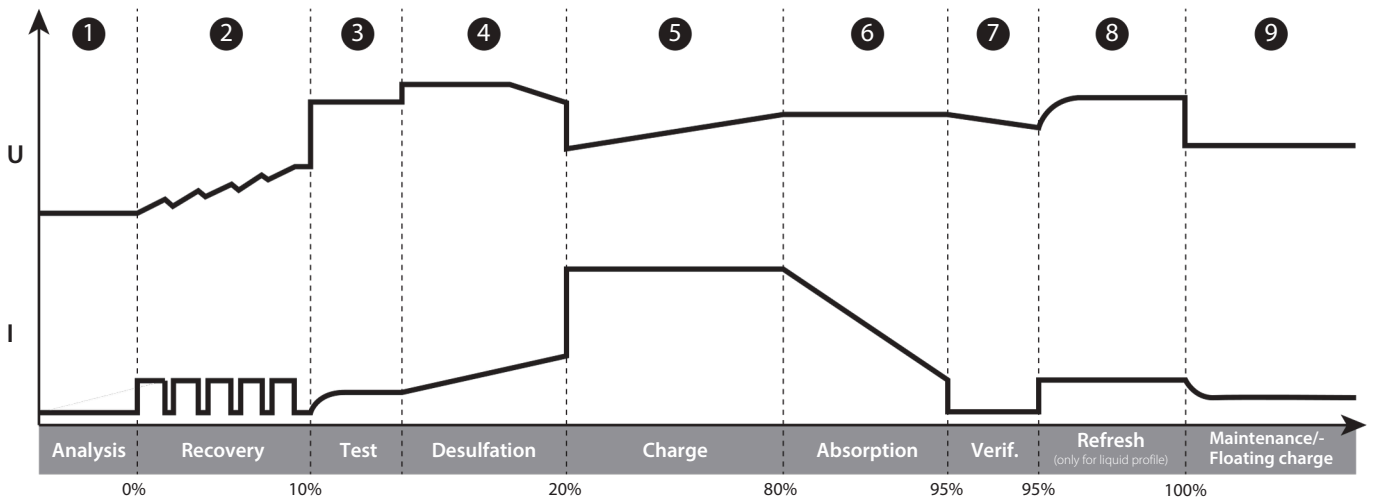

Step 1 : Analysis

Analyses the state of the battery (charge level, polarity inversion, wrong battery...)

Step 2 : Recovery

Recovering damaged elements after deep and prolonged discharge.

Step 3 : Test

Sulfated battery test

Step 4 : Desulfation

Battery desulfation algorithm.

Step 5 : Charge

Fast charge at maximum current to reach 80% charge level.

Step 6: Absorption

Constant voltage charge to reach 100% charge level.

Step 7: Verification

Check that the battery is holding its charge.

Step 8 : Refresh (only for liquid profile)

The charger supplies an additional current to create gas that will allow the electrolyte to be mixed and thus reconditioning the battery cells. During this phase, the battery may produce some water.

Step 9 : Maintenance/Floating charge

Maintains battery charge level at its maximum.

LFP Lithium charging curve:

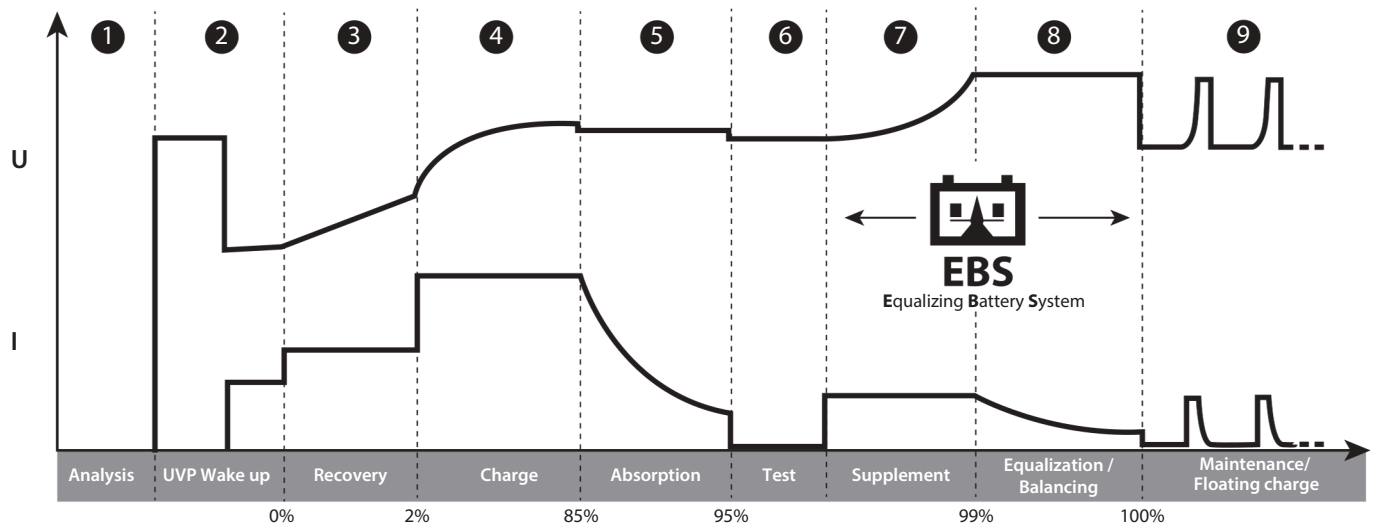

Step 1 : Analysis

Analyses the state of the battery (charge level, polarity inversion, wrong battery...)

Step 2: UVP Wake up

Reactivates batteries in UVP protection (Under Voltage Protection) Reduce current charge to reach 100% charge level.

Step 3: Recovery

Recovery algorithm following a deep discharge.

Step 4 : Charge

Maximum current fast charge to reach an 90% charge level.

Step 5: Absorption

Constant voltage charge to reach a 95% charge level.

Step 6 : Test

Charge conservation test.

Step 7 : Supplement

Step 8: Equalization / Balancing

Balancing the battery cells

Step 9: Maintenance/Floating charge

Maintain the battery charge level at its maximum.

POWER SUPPLY MODES: SHOWROOM / DIAG+

• Setting the mode:

- 1 Press the SELECT button for 3 seconds to activate the modification of the mode settings.
Use the arrows to change the value of the parameter.
- 2
- 3 Press the SELECT button to accept the value and move to the next parameter.

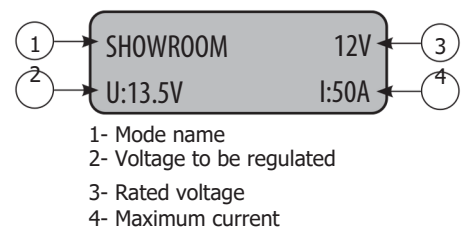
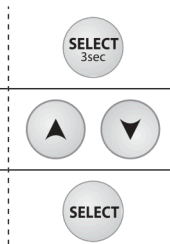

Power limitation: If the symbol «*» appears next to the current setting (eg «I: 50A *»), this indicates that the charger cannot deliver this current at the voltage set on the display. At this voltage level, the charger will be running at maximum power. However, this current could be delivered at lower voltage depending on the power output of the charger.

• Start of the charge:

- 1 To start the mode, press the START/STOP button.
If the AUTO-DETECT function is active, charging will start
- 2 During the mode, your GYSFLASH indicates the battery voltage and the current delivered by the charger.
- 3 Press the START/STOP button to stop the mode.

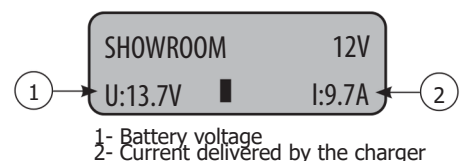
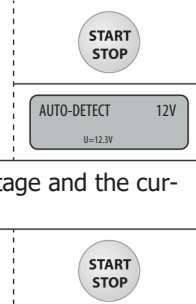

Precautions :

When starting the mode, a current displayed above 10 A means that your battery is discharged. The device will start charging automatically Check that there is no electrical consumer on the vehicle. Wait until the current supplied drops below 10 A before starting any action on the vehicle (use of the vehicle's electrical accessories, diagnostic operation, etc.).

Features of the power modes:

Mode	«No Battery» function	«Integrated charging» function	Abnormal undervoltage protection	Voltage adjustment
SHOWROOM	✓	✓	✓	12 V models [12V 12.7 V - 14.4 V 24 V models [6V 6.3 V - 7.2 V [24V 25.4 V - 28.8 V [36V 38.1 V - 43.2 V [48V 50.8 V - 57.6 V
DIAG+			✓	12 V models [12V 12.7 V - 14.8 V 24 V models [16V 14.4 V - 17.2 V [24V 25.4 V - 29.6 V [36V 38.1 V - 44.4 V [48V 50.8 V - 59.2 V

• **«No battery» function (not recommended):**

This function allows you to use the SHOWROOM power mode when there is no battery. To do this, press the START/STOP button for 3 seconds. The «No battery mode» indication is displayed for 3 seconds before forcing the power supply.



It is strongly recommended not to use the «no battery» function if a battery is present.

This function disables the «Integrated charging» function, as well as some of the protections such as abnormal undervoltage protection or disconnection detection.

In this configuration, reverse polarity can damage the vehicle electronics.

• **«Integrated charging» function:**

The SHOWROOM mode (outside of the «no battery» function) incorporates an automatic charging algorithm adapted to all types of batteries (lead and lithium), in order to guarantee an optimal charge level for demonstration vehicles. This function is perfectly compatible with the presence of consumers on the battery.

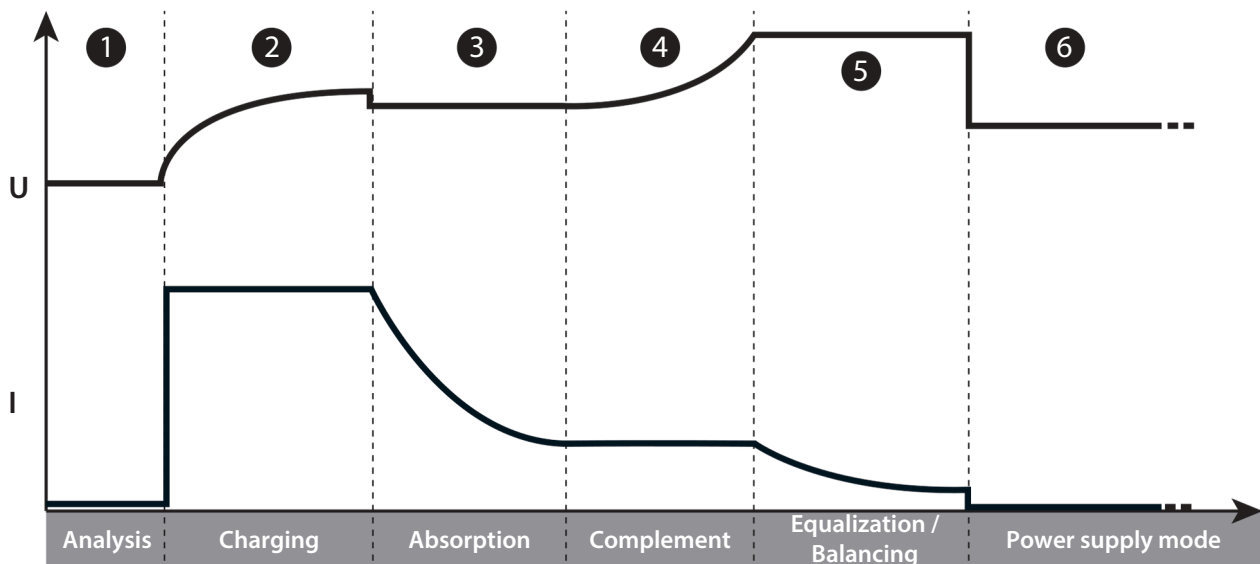

Step 1: Analysis

Analysis of the battery condition (charge level, inversion, etc.) polarity, wrong battery connected, etc.)

Step 2: Charging

Fast charging at maximum current until U1 is reached (ex: 13.8 V to 12V)

Step 3: Absorption

Charge under constant voltage U1 (ex: 13.8 V in 12V). Maximum duration 1 hour.

Step 4: Complement

Gradual increase of the voltage up to U2 (ex: 14.4 V to 12V). Maximum duration 2 hours.

Step 5: Equalization / Balancing

Maintaining the voltage U2 (ex: 14.4V at 12V). Maximum duration 2 hours.

Step 6: Power supply mode

Application of the selected voltage.

• **Abnormal undervoltage protection:**

This protection prevents the risk linked to possible short circuits or battery being too damaged. The charger will automatically stop if the voltage is abnormally low for more than 10 minutes.

TESTER MODE

General navigation :

- 1 Use the arrows to select the test to be performed
- 2 Press the START/STOP button to start the test

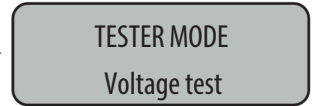
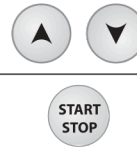

• **Voltage test:**

This mode allows you to view the voltage at the terminals of the charging clamps and thus use your GYSFLASH as a voltmeter, in order to measure the battery voltage.

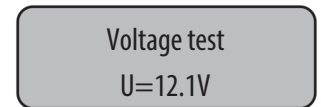

• **Start-up test:**

The purpose of this mode is to evaluate the state of a vehicle starting system (starter + battery) when the engine is turned on. This test must be done with the battery connected to the vehicle.

- 1 Use the arrows to select the nominal voltage of the vehicle battery
- 2 Press the SELECT button to confirm
- 3 Connect the clamps to the vehicle battery
- 4 Start the engine by turning the ignition key
- 5 The charger automatically detects the engine start attempt and runs a calculation algorithm to determine the state of the start system.

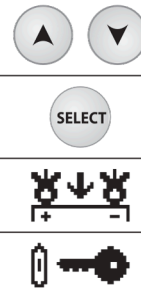

Test result: The charger indicates the minimum value of the battery voltage perceived during the engine start phase, as well as the status of the start system in the form of a gauge.



• **Alternator test :**

This mode is used to determine the condition of the alternator in the vehicle. This test is performed on a vehicle with the engine running.

- 1 Use the arrows to select the nominal voltage of the vehicle battery
- 2 Press the SELECT button to confirm

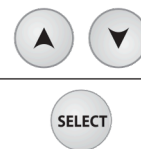

Test result: The charger indicates the voltage provided by the vehicle alternator, as well the alternator status in the form of a gauge.



PROTECTIONS

This device is protected against short circuits and polarity reversals. It has an anti-spark system that prevents sparks when connecting the charger to the battery. The device will not deliver current if there is no battery detected (no voltage in the clamps). This charger is protected against handling errors by an internal fuse.

CONFIGURATION MENU

Navigation :

1	Press the MODE button for 3 seconds to access the Configuration Menu	
2	Use the arrows to scroll through the different parameters	
3	Press the SELECT button to select the parameter or enter the submenu.	
4	When a parameter is flashing, use the arrows to change its value	
5	Confirm the parameter value by pressing SELECT again	

Languages :

Selecting the display language.

Sound:

Turning the unit's sound on (ON) or off (OFF).

Auto-Restart:

Enable (ON) or disable (OFF) the AUTO-RESTART function. This function automatically restarts the charger in the event of a power failure.

Auto-Detect :

Enable (ON) or disable (OFF) the AUTO-DETECT function. This function automatically starts a charge when a battery is connected to the charger.

Date :

Setting the date and time.

Cable calibration :

Procedure for calibrating the charging cables of the device, so that the charger optimally compensates for the voltage drop due to the cables. It is strongly recommended to perform this procedure at least once a year and each time the charging cables are replaced.

Calibration procedure :

1	Press SELECT to enter the CABLE CALIBRATION submenu							
2	Short-circuit the clamps							
<p> Ensure that the metal parts of the jaws to which the cables are attached are in good contact with each other.</p>								
<table border="0"> <tr> <td></td> <td></td> <td></td> </tr> <tr> <td>OK</td> <td>NOK</td> <td>NOK</td> </tr> </table>						OK	NOK	NOK
OK	NOK	NOK						
3	Press START/STOP to start the calibration							
4	<p> : The calibration was successful.</p> <p>Err19: Cable_NOK : A problem occurred during cable calibration. Check that the cables are in good condition and correctly short-circuited and repeat the operation.</p>							

USB USB connectivity :

Sub-menu to access USB features.

Power limits:

In some cases, it is necessary to limit the power of the unit to protect the system. This menu allows you to restrict P_max and I_max as follows:

- **P_max** : Maximum power consumed by the charger from the mains.

Important : We strongly recommend that you set this value according to the power available on the power supply, as shown in the table below:

Value of P_max to be set		Maximum current allowed by the electrical supply						
		5 A	6 A	8 A	10 A	13 A	15 A	16 A
Nominal mains voltage	100 Vac			600 W	750 W	1000 W	1200 W	
	110-127 Vac		550 W	700 W	900 W	1200 W	1500 W	
	220-240 Vac	1000 W	1200 W	1600 W	2000 W	2500 W	2950 W	3200 W

Specific recommendations depending on the country:

- **Japan** mains supply 100 V / 15 A **P_max ≤ 1200 W**
- **United Kingdom / Switzerland** mains supply 230 V / 13 A **P_max ≤ 2500 W**

- **I_max** : Maximum current supplied by the charger as output.

Important : It may be necessary to limit the output current if, for example, the cross-section of the charging cables or the output connectors are not suitable for the maximum charging current.

Multi-Charger mode:

This menu allows you to combine several chargers for the following uses:

- Single: Normal single charger mode.
 - Parallel: Allows several chargers to be grouped together to increase power output.
 - Equalise: Used to balance the charge level of two to four batteries (independent or in series).
 - Single/Equalise: Each time the charger is switched on, the user is asked to choose whether to operate in Single or Equalise mode.
- Refer to the SHM - Smart Hub Module (025981) manual for more details on Parallel and Equalise

Important: If the charger is blocked by displaying SLAVE, this means that it is configured in Parallel or Equalize. To exit this configuration, press the MODE button for 3 seconds, then select «Single» from the menu that appears.

Identification :

This menu is used to set the Charge Identification. (Refer to page 29 for more details on Charge Identification).

/	Set the type of keyboard and barcode reader used (AZERTY, QWERTY, QWERTZ, etc.). Important: Make sure that the barcode reader is configured in the same way as the charger.
N° Battery	Set the number of batteries for identification.

Note: This menu is only accessible if a barcode reader or keyboard is connected to the charger.

i Information :

This menu displays information about your Gysflash:

- Device name
- Hardware/software versions
- Serial number

USB CONNECTIVITY

Your GYSFLASH is equipped with USB connectivity that extends its functionality by creating custom configurations on your computer that can then be downloaded to the device via a simple USB stick. The custom configuration allows you to add, delete or modify charging modes and profiles, so that your charger can be adapted to your needs.

USB connectivity also gives you the ability to retrieve the history and data of more than 100 recharge on a USB stick and run them on a spreadsheet.

Navigation :

1	Use the arrows to scroll through the different submenus or files available	
2	Press the SELECT button to enter the submenu or select a file.	
3	Use the MODE button to return to the previous submenu	

Import a new configuration:

This function allows you to download a new configuration («.gfc» file) into the charger via the USB key.

1	First, make sure that the ".gfc" file corresponding to the new configuration is present on the USB key. This file must not be located in a folder or subfolder of the USB stick.	
2	Connect the USB stick to the charger.	
3	Enter the "Import CONFIG" submenu	
4	Select the file to download	
5	Confirm the download of the file	
6	The charger will then download the new configuration.	



Export a configuration on a USB key:

This function allows you to save the current charger configuration («.gfc» file) to the USB stick.

1	Connect the USB stick to the charger.	
2	Enter the "Export CONFIG" submenu	
3	Confirm that the configuration has been saved.	
4	The charger will then save its current configuration on the USB stick. (file "Config_file.gfc").	

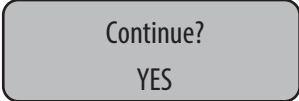

Restore the previous configuration:

This function allows you to restore the second to last charger configuration in case of a problem or error with the last downloaded configuration.

1	Enter the "Restore CONFIG" submenu	
2	Confirm the restoration of the configuration.	
3	The charger will then restore the penultimate configuration of the charger.	

Export charging data on USB stick:

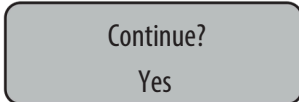



This function allows you to retrieve the charge history and data on a USB key, in order to be able to use them on a spreadsheet or other.

1	Enter the "Export DATA" submenu	
2	Confirm the recording of the charging data.	
3	The charger will then copy the charging data to the USB stick as files, « .CSV »	

Import identification file (.gfi) :

This function is used to download an identification configuration file («.gfi» file) to the charger via a USB stick.

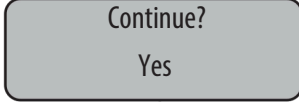
Note: Menu accessible only if a barcode reader or keyboard is connected to the charger.

1	First, make sure that the identification configuration file «.gfi» is present on the USB stick. This file must not be located in a folder or sub-folder on the USB stick.	
2	Plug the barcode reader or keyboard into the USB port on the charger.	
3	Enter the submenu «Import .gfi».	
4	Disconnect the barcode reader or keyboard from the USB port on the charger.	
5	Plug the USB stick into the charger.	
6	Select the file to download.	
7	Confirm the file download.	
8	The charger will then download the new configuration.	

Custom configuration

List of modes and profiles available for customization:

CHARGE MODE			
Charge type:	Charge profiles	Charging voltage	
Pb-CHARGE	normal	2.40 V/cell	Charging profile for lead batteries of the types Gel, MF, EFB, SLA...
	AGM	2.45 V/cell	Charging profile for most AGM lead-acid batteries including START and STOP. However, some AGM batteries require a lower voltage charge (Normal profile). Check the battery manual if in doubt.
	water	2.45 V/cell	Charging profile for open liquid-type lead-acid batteries with plug.
	Easy	2.40 V/cell	Charging profile dedicated to lead batteries that automatically adapts the charging current according to the size of the battery. However, for maximum charge optimization, it is recommended, when possible, to use normal, AGM or liquid charge curves.
	boost	2.42 V/cell	Maximum current charge for lead-acid battery. This type of charge is ultra-fast. Warning : this type of charge must remain occasional in order to preserve battery life.
	recovery+	2.40 - 2.50 V/cell	Charging profile for the recovery of severely damaged lead batteries. It is essential to recover the battery outside the vehicle to avoid damaging the vehicle electronics and in a well ventilated area. Caution: Recovery voltage up to 4.0 V/cell.
	Ca/Ca recov	2.45 - 2.66 V/cell	Charging profile for calcium battery recovery. The battery must be recovered outside the vehicle to avoid damaging the vehicle's electronics and in a well-ventilated area. Caution: Recovery voltage can reach up to 2.75 V/cell.
Li-CHARGE	LFP/LiFePO4	3.60 V/cell	Charging profile for Lithium batteries type LFP (Lithium Ferro Phosphate)
	Li-ion std	4.20 V/cell	Charging profile for standard lithium-ion batteries based on Manganese or Cobalt (NMC, LCO, LMO, MCO...)
	LFP cell+	3.60 V/cell	Charging profile dedicated to LFP (Lithium Ferro Phosphate) type lithium-ion cells with selection of the number of cells in series to be charged.
	Li-ion cell+	4.20 V/cell	Charging profile dedicated to standard lithium-ion cells based on Manganese or Cobalt (NMC, LCO, LMO, MCO...) with selection of the number of cells in series to be charged.
TRACTION	water	2.42 V/cell	Charging profile dedicated to open lead traction batteries for forklift trucks.
	gel	2.35 V/cell	Charging profile dedicated to gel-type traction batteries for forklift trucks.

POWER MODES	
Showroom	Maintains the battery's state of charge and supplies power when using the electrical consumers of a demonstration vehicle.
DIAG+	Supplies energy requirements during the vehicle diagnostic work.
DIAG+ (PRO)	Similar to DIAG+ mode but with 16V selection available
CHANGE BAT.	Allows to keep the vehicle power supply during battery replacement, in order to preserve the memory of the vehicle's ECUs. Caution: Reverse polarity during use can be harmful to the charger and vehicle electronics.
STARTER MODE	Starting aid for combustion vehicles. Allows the battery to be precharged and the charger to send the maximum current during the engine starting phase (the charger stops automatically after 30 minutes).
POWER SUPPLY	Allows the charger to be used as an adjustable stabilized power supply with high power. The voltage to be regulated and the current limitation are fully adjustable. Caution: Reverse polarity during use can be harmful to the charger and vehicle electronics.
Li-SUPPLY/LFP	Mode intended to supply lithium-ion cells of the LFP type (Lithium Ferro Phosphate) with selection of the number of cells in series, adjustment of the voltage and current to be applied.
Li-SUPPLY/Li-ion	Mode intended to supply standard lithium-ion batteries based on Manganese or Cobalt (NMC, LCO, LMO, MCO...) with selection of the number of cells in series, adjustment of the voltage and current to be applied.

MISCELLANEOUS	
TESTER MODE	Allows to check the state of the battery, to evaluate the starting of the vehicle as well as the operation of the alternator

GYS offers you predefined configurations adapted to each application.

These settings are available on the product page of the GYS website: Gysflash V01.00 ▾ >

Configuration file (gys.fr)	Applications	CHARGE MODE											POWER MODES							MIS-CELLA-NEOUS		
		Pb-CHARGE					Li-CHARGE			TRACTION			DIAG+ SHOWROOM	DIAG+ (PRO)*	CHANGE BAT.	POWER SUPPLY MODE	LI-SUPPLY/LFP	LI-SUPPLY/Li-ion	TESTER MODE			
		normal	AGM	water	Easy	Boost	Recovery+	Ca / Ca recov	LFP/LiFePO4	LFP cell	Li-ion std	Li-ion cell+									water	gel
GYS Original	Initial configuration of the charger	✓	✓	✓	✓				✓						✓	✓						✓
Car Extended	Extensive features for garages	✓	✓	✓	✓	✓	✓	✓	✓	✓					✓	✓	✓	✓				✓
Showroom Only	Simplified version for dealerships and demonstration vehicles													✓								
Pro Lithium	Professional of lithium battery								✓	✓	✓	✓						✓	✓	✓		
Traction	Forklift truck, electric pallet truck, stacker...												✓	✓								
Full Version	Full version	✓	✓	✓	✓	✓	✓	✓	✓	✓	✓	✓	✓	✓	✓	✓	✓	✓	✓	✓	✓	✓

✓ Only on 24 V and 48 V models.
* DIAG+ (Pro) - 16 V selection possible.

CONNECTIVITY MODULES

Your GYSFLASH is equipped with a SMC socket allowing you to connect various additional modules offered by GYS in order to further extend the possibilities of your charger.

Important: The use of the device's SMC port is reserved exclusively for industrial applications. Installation must be carried out in accordance with the recommendations in the instruction manual of the associated module.

CHARGE IDENTIFICATION

This feature uses the keypad and/or the barcode reader to assign specific information to each charge, such as customer name, vehicle model, VIN, battery number, etc. This information can then appear on the charging data history. This information can then be included in the charge data history.

<p>1 When the charge starts, your Gysflash asks if you want to identify the charge. Select «Yes» to enter the identification information.</p>	<div style="border: 1px solid gray; border-radius: 10px; background-color: #f0f0f0; padding: 10px; width: 80px; margin: 0 auto;"> Identifi- cation Oui </div>
<p>2 Enter the various identification data using the keypad and/or the barcode reader.</p>	<div style="border: 1px solid gray; border-radius: 10px; background-color: #f0f0f0; padding: 10px; width: 80px; margin: 0 auto;"> Customer name Morrison Jack </div>
<p>3 Press SELECT or the «Enter» key on the keypad to move on to the next item. The charger will then indicate whether the data is valid (✓) or not (✗). NB: Even if the information is invalid, you can continue on to the next item by pressing SELECT or the «Enter» key on the keypad again.</p>	<div style="border: 1px solid gray; border-radius: 10px; background-color: #f0f0f0; padding: 10px; width: 80px; margin: 0 auto;"> Customer name ✓ Morrison Jack </div>
<p>4 Use the arrows to navigate between the different pieces of identification data.</p>	<div style="display: flex; justify-content: center; gap: 10px;"> ▲ ▼ </div>
<p>Once identification is complete, your Gysflash may recommend that you modify certain charging parameters according to the data it has collected. You can then choose between the initial settings or the recommended settings.</p>	<div style="border: 1px solid gray; border-radius: 10px; background-color: #f0f0f0; padding: 10px; width: 80px; margin: 0 auto;"> Pb-CHARGE 12V liquid 50Ah </div>
<p>6 After the identification procedure, charging will start automatically.</p>	<div style="border: 1px solid gray; border-radius: 10px; background-color: #f0f0f0; padding: 10px; width: 80px; margin: 0 auto;"> Pb-CHARGE ■ 24% U=13.1V I=9.7A </div>

LIST OF ERROR CODES

Error code	Meaning	Solutions
Err01: Int_1 - Err02: Int_2 Err23: Int_3 - Err24: Int_4	Electronic problem Defective charger	Contact the reseller Have the fuse replaced by a qualified person
Err03: Fuse_NOK	Output fuse out of order	Contact the reseller
Err04: T>Tmax	Abnormal overheating	Connect the red clamp to the (+) and the black clamp to the (-) of the battery.
Err05: (+)(-)	The polarity has been reversed on the clamps	Disconnect the clamps
Err06: U>__V	Overvoltage detected at the clamp terminals	Check that the battery is correctly connected to the charger Check that the selected mode is compatible with the battery voltage (e. g. : 6 V battery in 24 V mode)
Err07: No_bat	Battery not connected	
Err08: U<__V	Abnormally low battery voltage	Charge the battery via CHARGE mode Battery to be replaced
		Check that the selected mode is compatible with the battery voltage (e. g. : 24 V battery in 12 V mode) Check the assembly
Err09: U>__V	Abnormally high battery voltage	Presence of a consumer on the battery disrupting the charge
Err10: U<2.0V	Short-circuit detected during the charge process	Battery to be replaced Presence of a consumer on the battery disrupting the charge
Err11: Time_Out	Triggering the time limit	Battery to be replaced
	Abnormally long charge	Battery to be replaced
Err12: Q>__Ah	Tripping the overcharge protection	Presence of a short circuit, check the assembly
Err13: U<__V	Abnormally low battery voltage when checking the charge	Battery to be replaced
Err14: Bat_UVP	Abnormally low battery voltage during UVP Wake up	Check that the selected mode is compatible with the battery voltage (e. g. : 24 V battery in 12 V mode) Battery to be replaced
Err15: U<__V	Battery too low	Battery to be replaced
		Battery to be replaced Check the assembly
Err16: Bat_NOK	Battery out of order	Charging cables to be replaced
Err17: Recov_NOK	Battery recovery failure	Incorrect connection, check the assembly
Err18: U>0V	Presence of a voltage at the clamp terminals when calibrating the cables	Presence of a short circuit, check the assembly
Err19: Cable_NOK	Cable calibration failure	Battery to be replaced
		Presence of a consumer on the battery
Err20: U<__V	Triggering of the abnormal undervoltage protection	Check that the USB key is correctly connected to the charger.
Err21: U<__V or Err22: U<__V	Abnormally low battery voltage during charging	Check that your files are present at the root of the USB key. Do not put them in a folder or sub-folder.
		The file you wish to download is corrupted. Delete and reinstall the file on the key.
?	Key not detected	Check that your files are at the root of the USB stick. Do not put them in a folder or sub-folder.
?	No configuration file (.gfc) is present on the key Corrupted file	Load cables to be replaced.
?	No identification file (.gfi) is present on the stick	Poor connection, check assembly (PHM). To switch back to single charger operation, select OFF for the Multi-Charger function.
Err27: Cable_NOK	Multi-charger mode : Parallel charging cables fail	No communication, check SHM mounting and SLAVE X charger configuration.
		To switch back to single charger operation, select OFF for the Multi-Charger function. Check that one of the batteries is not defective.
Err28: COM_NOK	Multi-charger mode : Communication failure between chargers	
Err32: Unbalanced	Equalise mode: Unbalanced batteries	

FIRMWARE UPDATE (.EGF)

Procedure Updating using a USB stick:

1. First, ensure that the '.egf' file corresponding to the new firmware is present on the USB key. This file must not be located in a folder or subfolder on the USB key.

Caution: The USB key must contain only one '.egf' file and must be formatted in FAT32.

2. Switch off the Gysflash using the On/Off switch. ②

3. Hold down the MODE button.

4. Switch on the Gysflash using the On/Off switch ② while holding down the MODE button until 'v01.xx USB Detection Please wait...' appears on the screen.

5. Connect the USB key to the Gysflash; the update will start automatically.

The progress of the update will be displayed on the screen.

6. When the update is complete, the Gysflash will display 'Update completed' and restart automatically after 3 seconds.

WARRANTY

The warranty covers faulty workmanship for 2 years from the date of purchase (parts and labour).

The warranty does not cover:

- Transit damage.
- Normal wear of parts (eg. : cables, clamps, etc..).
- Damages due to misuse (power supply error, dropping of equipment, disassembling).
- Environment related failures (pollution, rust, dust).

In case of failure, return the unit to your distributor together with:

- The proof of purchase (receipt etc ...)
- A description of the fault reported

FACE AVANT / FRONT / FRONTSEITE / DELANTERA / ПЕРЕДНЯЯ ПАНЕЛЬ / VOORKANT / FRONTALE

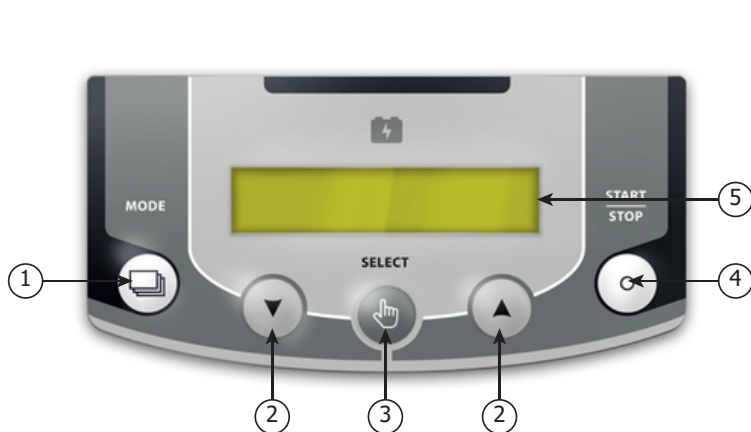

- 1** FR : Bouton Mode
EN : Button Mode
DE : Mode Knopf
ES : Botón Modo
RU : Кнопка Mode
NL : Modus knop
IT : Tasto Mode
- 2** FR : Boutons + ou -
EN : Buttons + or -
DE : + oder - Knöpfe
ES : Botones + o -
RU : Кнопки + или -
NL : Knop + of -
IT : Tasti + o -
- 3** FR : Bouton Select
EN : Button Select
DE : Select Knopf
ES : Botón Select
RU : Кнопка Select
NL : Select knop
IT : Tasto Select
- 4** FR : Bouton Start/Stop
EN : Button Start/Stop
DE : Start/Stop Knopf
ES : Botón Start/Stop
RU : Кнопка Start/Stop
NL : Start/Stop knop
IT : Tasto Start/Stop
- 5** FR : Afficheur
EN : Display
DE : Display
ES : Pantalla
RU : Индикатор
NL : Weergavescherm
IT : Schermo

CONNECTIQUES / CONNECTORS / ANSCHLÜSSE / CONECTORES / КОННННЕКТОРЫ / CONNECTORS / CONNETTORI

GYSFLASH 51.12 / 101.12 CNT

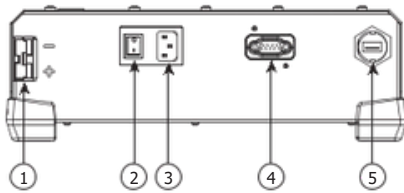

GYSFLASH 121.12 / 101.24 / 125.12 CNT

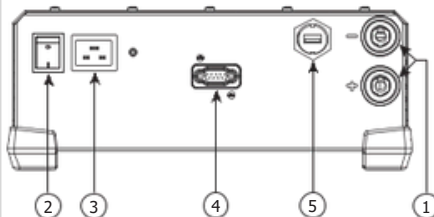

GYSFLASH 51.48 CNT

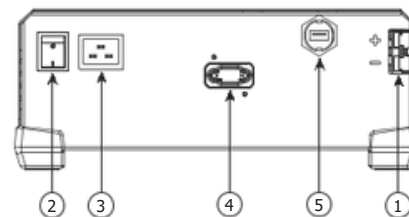

GYSFLASH 123.12 / 103.24 CNT

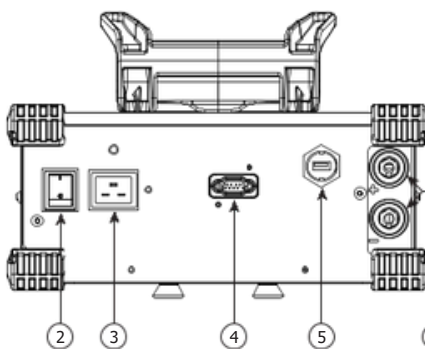

GYSFLASH 53.48 CNT

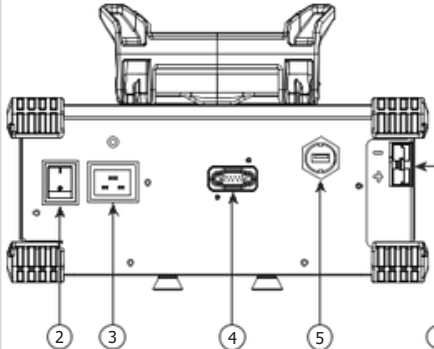

GYSFLASH 53.24 / 103.12 / 25.48 CNT

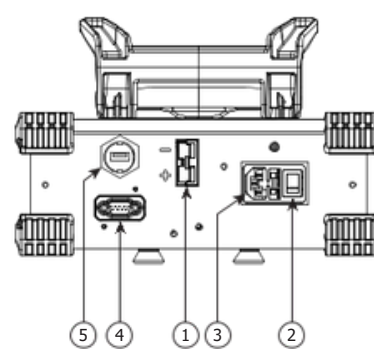

- 1** FR : Connecteur de charge
EN : Charging connector
DE : Ladeanschluss
ES : Conector de carga
RU : Коннектор зарядки
NL : Aansluiting laden
IT : Connettore di carica
- 2** FR : Interrupteur marche/arrêt
EN : On/off switch
DE : EIN/AUS Schalter
ES : Interruptor encendido / apagado
RU : Переключатель ВКЛ/ВЫКЛ
NL : Schakelaar aan/uit
IT : Interruttore avvio/stop
- 3** FR : Prise secteur
EN : Mains plug
DE : Netzsteckdose
ES : Clavija de corriente
RU : Сетевая вилка
NL : Stopcontact
IT : Spina
- 4** FR : Connecteur pour module additionnel GYS (type Sub-D 9)
EN : Connector for GYS additional module (type Sub-D 9)
DE : Anschluss für zusätzlichen Modul GYS (Typ Sub-D 9)
ES : Conector para modulo adicional GYS (tipo Sub-D9)
RU : Коннектор для дополнительного модуля GYS (типа Sub-D 9)
NL : Aansluiting voor extra module GYS (type Sub-D 9)
IT : Connettore per modulo aggiuntivo GYS (tipo Sub-D 9)
- 5** FR : Connecteur USB
EN : USB connector
DE : USB-Anschluss
ES : Conector USB
RU : Коннектор USB
NL : USB aansluiting
IT : Connettore USB

**MONTAGE FIXATION CORDON / CORD FASTENER MOUNTING / MONTAGE EINE SCHNURBEFESTIGUNG /
INSTALACIÓN SOPORTE CABLE DE ALIMENTACIÓN / УСТАНОВКА ДЕРЖАТЕЛЯ ШНУРА ПИТАНИЯ /
INSTALLATIE VAN DE NETSNOERHOUDER / INSTALLAZIONE DEL FISSAGGIO PER CORDONE SPERONATO**

GYSFLASH 121.12 CNT FV / 123.12 CNT FV / 125.12 CNT FV / 101.24 CNT FV / 103.24 CNT FV / 51.48 CNT FV / 53.48 CNT FV

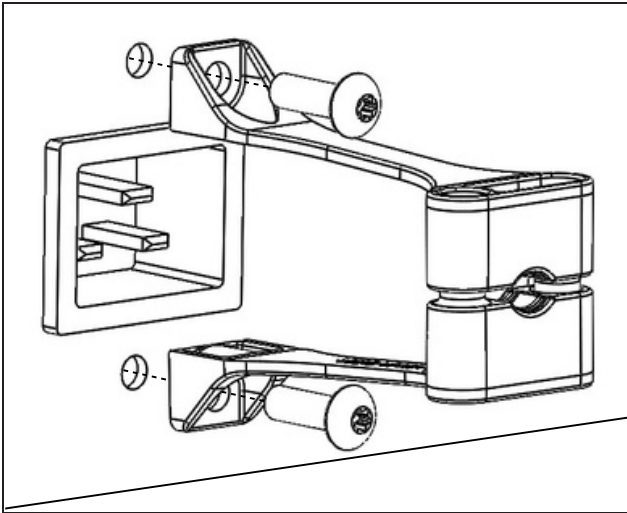
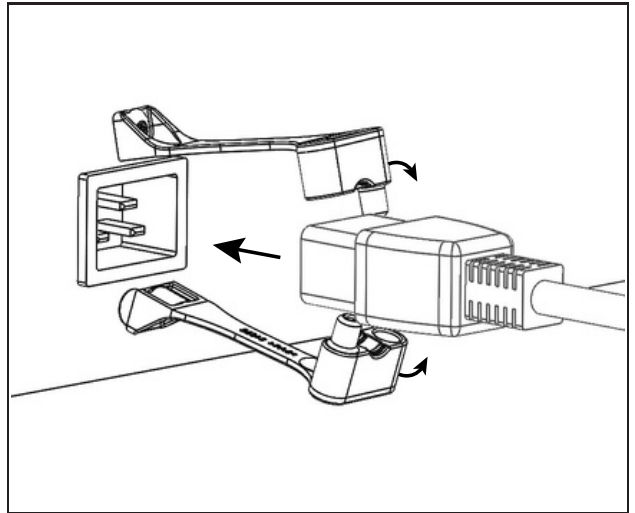
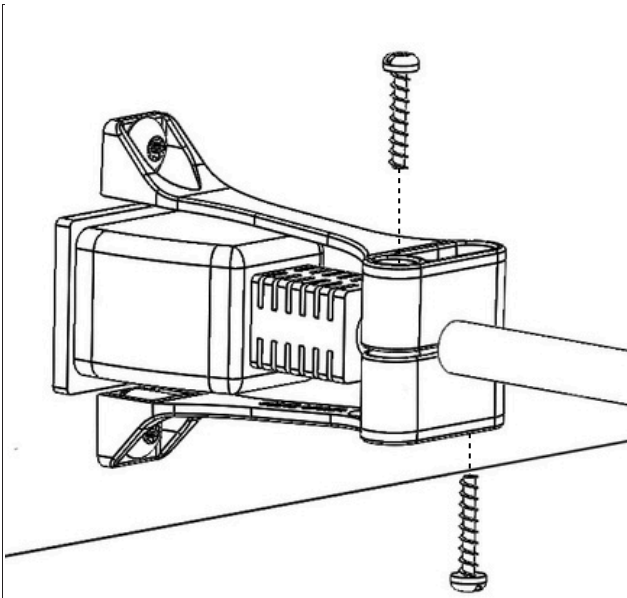
1**2****3**



GYS France

Headquarter 1, rue de la Croix des
Landes - CS



54159 53941

Saint-berthevin Cedex France
+33 2 43 01 23 60
www.gys.us



US Importer

Innovative Solutions CRTE, Corp
101 Alexander Ave, Suite 2
Pompton Plains, NJ 07444

973-768-9812

www.innovativecrte.com
sales@inovativecrte.com

Distributed by:

**PASSION
DRIVES
US**

