

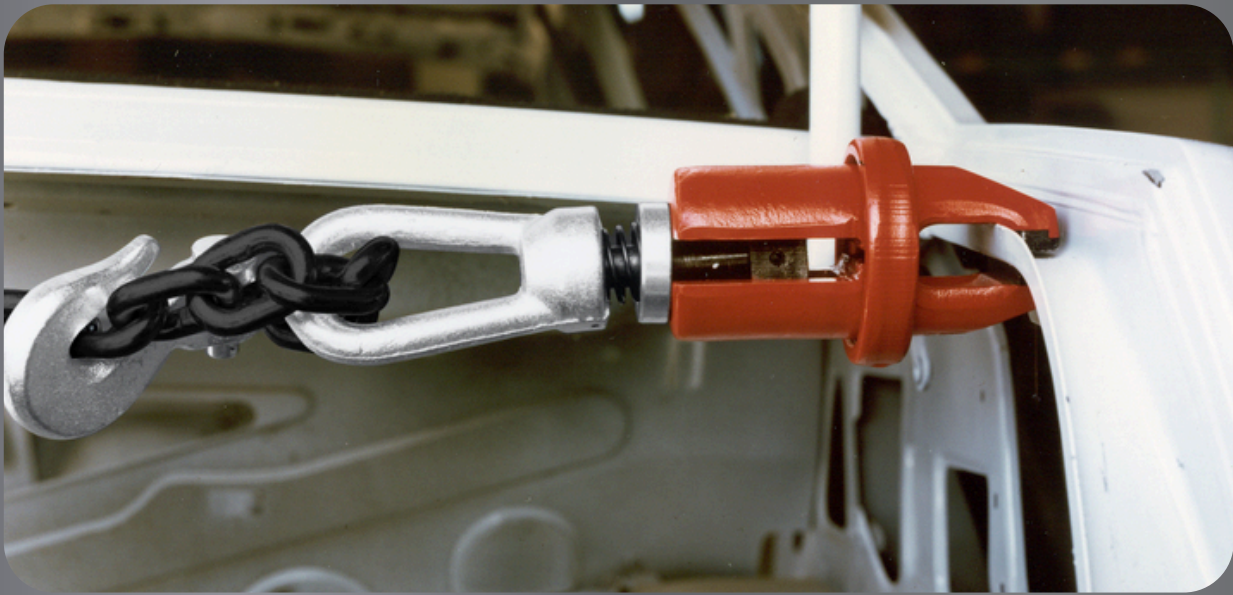

Skuba | Art. 121



55 mm Self-Locking Pull Clamp (No Hinge)

Interchangeable
jaws

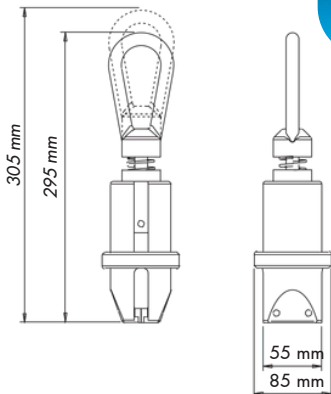

The Skuba 55 mm Self-Locking Pull Clamp is engineered for fast, secure attachment without the need to screw onto the body panel. Its self-locking design grips firmly in place, improving efficiency while reducing setup time. The clamp features interchangeable, knurled jaws made from hardened, wear-resistant steel for long service life and reliable holding power. Instead of a traditional hinge, the two clamp shells are joined by a forged and precision-turned steel ring, delivering superior strength and durability under heavy pulling loads.

At the core of the design is a self-centering locking mechanism, composed of a trapezoidal cone and a spring-loaded threaded pin. This mechanism is continuously held in position by machined seats within the two shells, preventing movement or disengagement during use.

Forged from high-strength steel, the Skuba pull clamp is built for demanding collision-repair and frame-straightening applications where strength, reliability, and speed matter.

Technical specifications		
Row Material		high-grade steel
Pull strength	ton	6
Jaws width	mm	55
Weight	Kg	3,2



Official U.S. importer partner:
Innovative Solutions CRTE, Corp
101 Alexander Ave, Suite 2
Pompton Plains, NJ 07444



ONE BOARD. NINE SOLUTIONS.

The Complete Stanzani Pulling System



4-10 TON PULLING COVERAGE • FORGED HIGH-GRADE STEEL • INTERCHANGEABLE HARDENED TEETH



ONE BOARD. NINE SOLUTIONS. The Complete Stanzani Pulling System

Professional collision repair requires more than one clamp. **It requires a complete pulling system engineered for every type of structural repair.**

The Stanzani 9-Piece Clamp Board brings together nine specialized pulling tools into one organized workstation. From tight-access structural pulls to heavy-duty frame corrections, each clamp is engineered to deliver **controlled pulling force with maximum grip on modern vehicle structures.**

Manufactured in Italy from high-grade steel, Stanzani clamps are designed to remain in service for years. Replaceable hardened teeth, serviceable components, and precision machining ensure that technicians can maintain peak performance without resorting to improvised hardware or generic replacements.

Instead of piecing together mismatched tools, technicians get a complete pulling solution mounted and ready for use.

BUILT FOR MODERN COLLISION REPAIR

- 100% Made in Italy
- High-grade hardened steel construction
- Interchangeable Teeth
- System pull range from **4-ton to 10-ton**
- Engineered for modern vehicle materials including HSS
- Precision-machined jaw geometry **prevents clamp slippage** during high-force pulls

BUILT FOR SAFETY & SERVICEABILITY

- Replaceable hardened teeth maintain proper grip geometry
 - Fully serviceable components extend tool life
 - Factory replacement consumables always available
 - Eliminates unsafe improvised repairs using generic hardware
- Stanzani clamps are engineered to be maintained – not improvised.**

View the full Stanzani clamp lineup and build your complete pulling system.



SCAN HERE

Complete Pulling System Includes:

All clamps shown mount to the included wall board with dedicated hooks. Mounting hardware not included.

Autoblock Magnum [Art. 134]

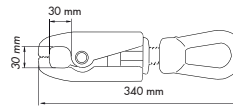

- 10-ton
- Interchangeable Jaws
- 5 Kg | 11 lbs

Applications: Heavy structural pulls, frame rail correction, and high-force pulls on reinforced structural components.



Skuba Clamp [Art. 121]



- 6-ton
- Interchangeable Jaws
- 3.2 Kg | 7 lbs

Applications: Pinch weld pulls, rocker panel repairs, and tight-access structural pulling points.

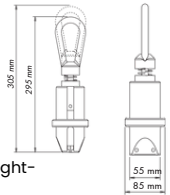

Autoblock Clamp 59mm [Art. 128]

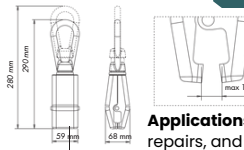

- 6-ton
- Interchangeable Jaws
- 3.5 Kg | 7.72 lbs

Applications: Pinch weld pulls, rocker panel repairs, and tight-access structural pulling points.



Shark Clamp [Art. 120]



- 6-ton
- Interchangeable Jaws
- 3 Kg | 6.61 lbs

Applications: Raised panel edges, protruding flanges, and areas where traditional clamps cannot seat flat.

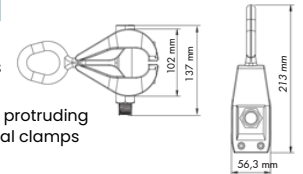

Right Angle Pull Clamp [Art. 133]

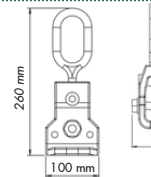

- 10-ton
- Interchangeable Jaws
- 3.7 Kg | 8.2 lbs

Applications: Perpendicular pulls on frame rails, pillars, and structural members where pulling direction must change.



Swivel Pull Clamp [Art. 135]



- 5-ton
- Interchangeable Jaws
- 3.8 Kg | 8.4 lbs

Applications: Multi-directional pulls on quarter panels, rocker panels, and areas requiring angle adjustments.

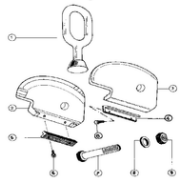

Universal Pull Clamp [Art. 131]

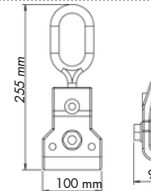

- 10-ton
- Interchangeable Jaws
- 3.3 Kg | 7.3 lbs

Applications: General body pulling, structural straightening, and everyday collision repair pulls.

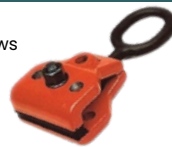

Rapidhook [Art. 136]



- 7-ton
- Interchangeable Jaws
- 2.1 Kg | 4.6 lbs

Applications: Fast chain attachment points, quick setup for pulling operations, and connecting chains.

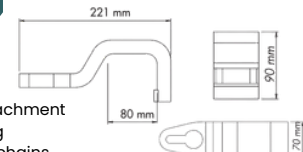

Pull Plier [Art. 144]

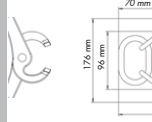

- 4-ton
- Interchangeable Jaws
- 3.2 Kg | 7 lbs

Applications: Small panel pulls, sheet metal corrections, and tight-space repairs where larger clamps cannot fit.

