

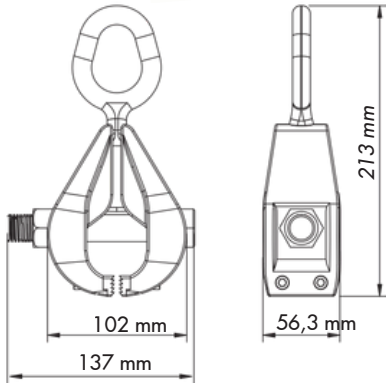

SHARK Ref. 120



Interchangeable jaws



The Shark Pull Clamp:

Unmatched Precision for Heavy-Duty Extraction

Engineered from high-grade forged steel, the Shark pull clamp is designed to tackle the most demanding structural repairs. Its unique deep-reach profile allows for a secure grip even on protruding or raised edges that standard clamps can't handle.

Safety is at the core of the Shark's design. Featuring a specialized seat within the semi-clamps, the eyebolt pulling mechanism remains locked in a centered position, virtually eliminating the risk of slippage during high-tension operations. Rated for a 6-ton pulling capacity, this clamp is a powerhouse in any workshop. While the hardened steel toothed jaws are built for maximum longevity, they are fully interchangeable, ensuring your equipment stays in peak condition for years to come.

Technical Specifications		120
Raw Material		High-grade steel
Pull strength	ton	6
Jaws width	mm	55
Weight	Kg	3



Official U.S. importer partner:
Innovative Solutions CRTE, Corp
101 Alexander Ave, Suite 2
Pompton Plains, NJ 07444



ONE BOARD. NINE SOLUTIONS.

The Complete Stanzani Pulling System



4-10 TON PULLING COVERAGE • FORGED HIGH-GRADE STEEL • INTERCHANGEABLE HARDENED TEETH



ONE BOARD. NINE SOLUTIONS. The Complete Stanzani Pulling System

Professional collision repair requires more than one clamp. **It requires a complete pulling system engineered for every type of structural repair.**

The Stanzani 9-Piece Clamp Board brings together nine specialized pulling tools into one organized workstation. From tight-access structural pulls to heavy-duty frame corrections, each clamp is engineered to deliver **controlled pulling force with maximum grip on modern vehicle structures.**

Manufactured in Italy from high-grade steel, Stanzani clamps are designed to remain in service for years. Replaceable hardened teeth, serviceable components, and precision machining ensure that technicians can maintain peak performance without resorting to improvised hardware or generic replacements.

Instead of piecing together mismatched tools, technicians get a complete pulling solution mounted and ready for use.

BUILT FOR MODERN COLLISION REPAIR

- 100% Made in Italy
- High-grade hardened steel construction
- Interchangeable Teeth
- System pull range from **4-ton to 10-ton**
- Engineered for modern vehicle materials including HSS
- Precision-machined jaw geometry **prevents clamp slippage** during high-force pulls

BUILT FOR SAFETY & SERVICEABILITY

- Replaceable hardened teeth maintain proper grip geometry
 - Fully serviceable components extend tool life
 - Factory replacement consumables always available
 - Eliminates unsafe improvised repairs using generic hardware
- Stanzani clamps are engineered to be maintained – not improvised.**

View the full Stanzani clamp lineup and build your complete pulling system.



SCAN HERE

Complete Pulling System Includes:

All clamps shown mount to the included wall board with dedicated hooks. Mounting hardware not included.

Autoblock Magnum [Art. 134]

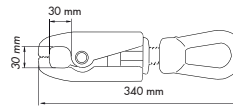

- 10-ton
- Interchangeable Jaws
- 5 Kg | 11 lbs

Applications: Heavy structural pulls, frame rail correction, and high-force pulls on reinforced structural components.



Skuba Clamp [Art. 121]



- 6-ton
- Interchangeable Jaws
- 3.2 Kg | 7 lbs

Applications: Pinch weld pulls, rocker panel repairs, and tight-access structural pulling points.

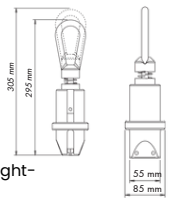

Autoblock Clamp 59mm [Art. 128]

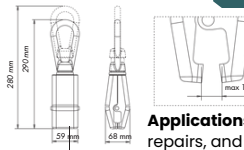

- 6-ton
- Interchangeable Jaws
- 3.5 Kg | 7.72 lbs

Applications: Pinch weld pulls, rocker panel repairs, and tight-access structural pulling points.



Shark Clamp [Art. 120]



- 6-ton
- Interchangeable Jaws
- 3 Kg | 6.61 lbs

Applications: Raised panel edges, protruding flanges, and areas where traditional clamps cannot seat flat.

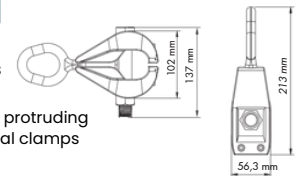

Right Angle Pull Clamp [Art. 133]

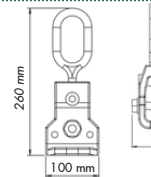

- 10-ton
- Interchangeable Jaws
- 3.7 Kg | 8.2 lbs

Applications: Perpendicular pulls on frame rails, pillars, and structural members where pulling direction must change.



Swivel Pull Clamp [Art. 135]



- 5-ton
- Interchangeable Jaws
- 3.8 Kg | 8.4 lbs

Applications: Multi-directional pulls on quarter panels, rocker panels, and areas requiring angle adjustments.

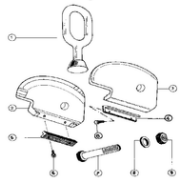

Universal Pull Clamp [Art. 131]

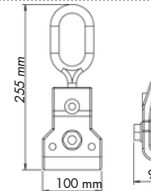

- 10-ton
- Interchangeable Jaws
- 3.3 Kg | 7.3 lbs

Applications: General body pulling, structural straightening, and everyday collision repair pulls.

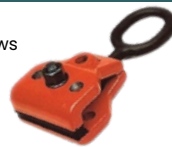

Rapidhook [Art. 136]



- 7-ton
- Interchangeable Jaws
- 2.1 Kg | 4.6 lbs

Applications: Fast chain attachment points, quick setup for pulling operations, and connecting chains.

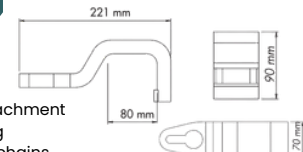

Pull Plier [Art. 144]

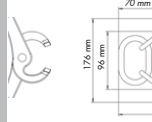

- 4-ton
- Interchangeable Jaws
- 3.2 Kg | 7 lbs

Applications: Small panel pulls, sheet metal corrections, and tight-space repairs where larger clamps cannot fit.

