

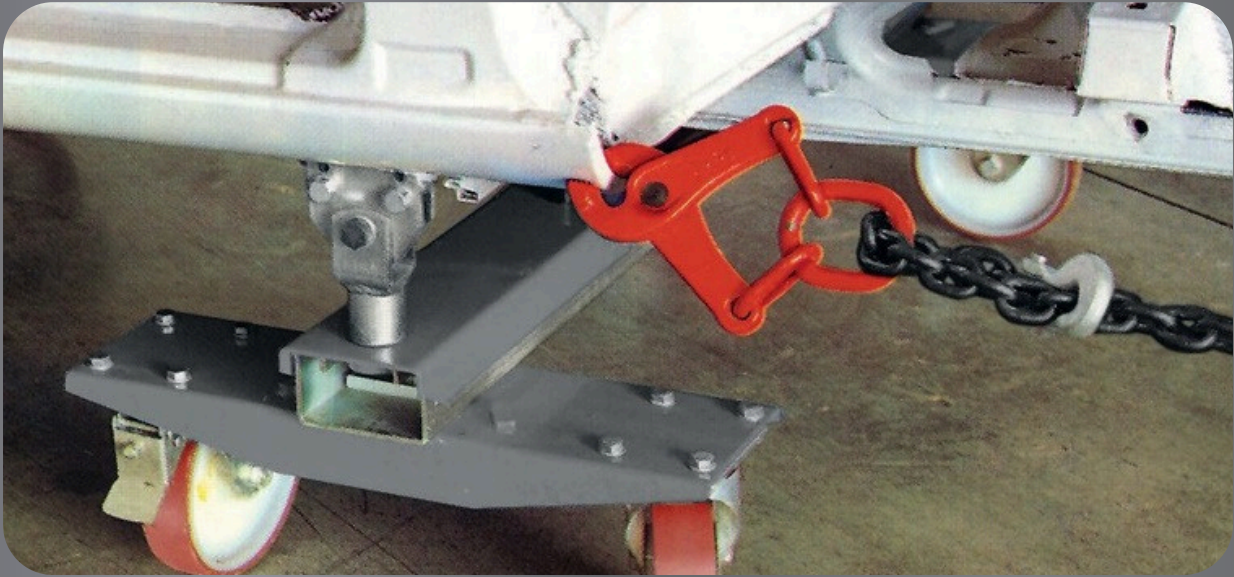

TENAGLIA | PULL PLIER Art. 144



The Pull Plier Pull Clamp:

The Stanzani Pull Plier is engineered with a compact profile and a wide-opening jaw, this forged steel tool is specifically designed to reach deep into difficult areas like side sills and inner wheel houses. Despite its nimble size, it doesn't compromise on strength.

Rated for a 4-ton pulling capacity, it features aggressive knurling on its tempered jaws to ensure a non-slip, "bite-like" grip on the sheet metal. It's the essential tool for technicians who need to balance heavy-duty power with surgical precision in tight spots.

Built for the rigors of a high-volume body shop, the Ref. 144 is forged from high-tensile steel for maximum durability. Its design focuses on a "low-profile, high-tension" philosophy, allowing for reliable structural pulls where clearance is minimal.

- **Hardened Tempered Jaws:** The jaws are heat-treated to resist wear and maintain a sharp, biting edge over years of service.
- **Wide Aperture:** The unique hinge design allows for a generous opening, accommodating various metal thicknesses.
- **Certified Strength:** Rigorously tested to withstand 4 tons of pulling force.
- **Compact & Lightweight:** At just 3.2 kg, it is easy to position with one hand, increasing technician efficiency.

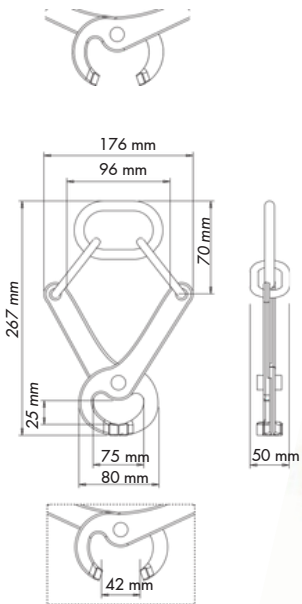

Technical Specifications		144
Raw Material		High-grade steel
Pull strength	ton	4
Weight	Kg	3.2





ONE BOARD. NINE SOLUTIONS.

The Complete Stanzani Pulling System



4-10 TON PULLING COVERAGE • FORGED HIGH-GRADE STEEL • INTERCHANGEABLE HARDENED TEETH



Complete Pulling System Includes:

All clamps shown mount to the included wall board with dedicated hooks. Mounting hardware not included.

Autoblock Magnum [Art. 134]

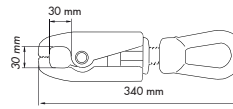

- 10-ton
- Interchangeable Jaws
- 5 Kg | 11 lbs

Applications: Heavy structural pulls, frame rail correction, and high-force pulls on reinforced structural components.



Skuba Clamp [Art. 121]



- 6-ton
- Interchangeable Jaws
- 3.2 Kg | 7 lbs

Applications: Pinch weld pulls, rocker panel repairs, and tight-access structural pulling points.

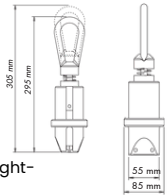

Autoblock Clamp 59mm [Art. 128]

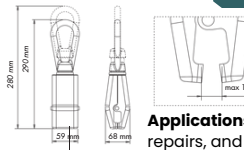

- 6-ton
- Interchangeable Jaws
- 3.5 Kg | 7.72 lbs

Applications: Pinch weld pulls, rocker panel repairs, and tight-access structural pulling points.



Shark Clamp [Art. 120]



- 6-ton
- Interchangeable Jaws
- 3 Kg | 6.61 lbs

Applications: Raised panel edges, protruding flanges, and areas where traditional clamps cannot seat flat.

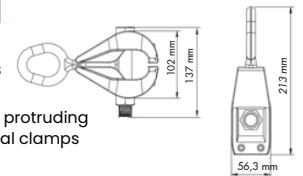

Right Angle Pull Clamp [Art. 133]

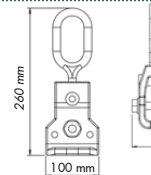

- 10-ton
- Interchangeable Jaws
- 3.7 Kg | 8.2 lbs

Applications: Perpendicular pulls on frame rails, pillars, and structural members where pulling direction must change.



Swivel Pull Clamp [Art. 135]



- 5-ton
- Interchangeable Jaws
- 3.8 Kg | 8.4 lbs

Applications: Multi-directional pulls on quarter panels, rocker panels, and areas requiring angle adjustments.



Universal Pull Clamp [Art. 131]

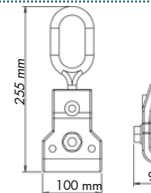

- 10-ton
- Interchangeable Jaws
- 3.3 Kg | 7.3 lbs

Applications: General body pulling, structural straightening, and everyday collision repair pulls.

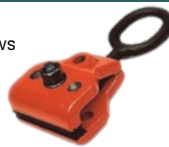

Rapidhook [Art. 136]



- 7-ton
- Interchangeable Jaws
- 2.1 Kg | 4.6 lbs

Applications: Fast chain attachment points, quick setup for pulling operations, and connecting chains.

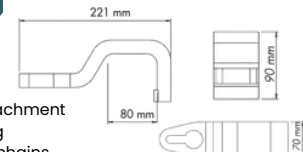

Pull Plier [Art. 144]

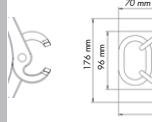

- 4-ton
- Interchangeable Jaws
- 3.2 Kg | 7 lbs

Applications: Small panel pulls, sheet metal corrections, and tight-space repairs where larger clamps cannot fit.



ONE BOARD. NINE SOLUTIONS. The Complete Stanzani Pulling System

Professional collision repair requires more than one clamp. **It requires a complete pulling system engineered for every type of structural repair.**

The Stanzani 9-Piece Clamp Board brings together nine specialized pulling tools into one organized workstation. From tight-access structural pulls to heavy-duty frame corrections, each clamp is engineered to deliver **controlled pulling force with maximum grip on modern vehicle structures.**

Manufactured in Italy from high-grade steel, Stanzani clamps are designed to remain in service for years. Replaceable hardened teeth, serviceable components, and precision machining ensure that technicians can maintain peak performance without resorting to improvised hardware or generic replacements.

Instead of piecing together mismatched tools, technicians get a complete pulling solution mounted and ready for use.

BUILT FOR MODERN COLLISION REPAIR

- 100% Made in Italy
- High-grade hardened steel construction
- Interchangeable Teeth
- System pull range from **4-ton to 10-ton**
- Engineered for modern vehicle materials including HSS
- Precision-machined jaw geometry **prevents clamp slippage** during high-force pulls

BUILT FOR SAFETY & SERVICEABILITY

- Replaceable hardened teeth maintain proper grip geometry
 - Fully serviceable components extend tool life
 - Factory replacement consumables always available
 - Eliminates unsafe improvised repairs using generic hardware
- Stanzani clamps are engineered to be maintained – not improvised.**

View the full Stanzani clamp lineup and build your complete pulling system.



SCAN HERE